

Unsupported Boom Type Bottom Loader

Designed to provide flexible long-range operation, this heavy-duty configuration is both reliable and easy to use. A minimum of five swivel planes of rotation offer complete flexibility in making tight connections for loading and unloading rail cars and tank trucks, and servicing aviation refuelers. The outboard swivel and arm adjusts for any changes in elevation or tilting that may result as the vehicle is loaded or unloaded.

The unsupported boom type loader is extremely versatile and many variations are possible. It can be equipped with dry disconnect coupler, union, quick coupling, or other customer specified end fitting to make connections on the side, at the rear, or underneath the vehicle. The intermediate swivel is often inverted to achieve the low profile and clearances needed to connect to the underside of a rail car.

Typically installed at or near ground level, arms of varying lengths can be mounted on staggered risers to achieve crossover and neat compact storage of multiple arms in a confined space.

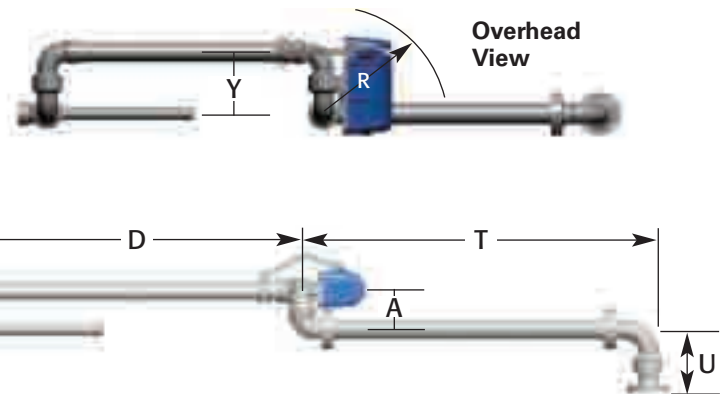

Benefits

- Easy to operate/maneuver
- Accommodates changes in elevation
- Can be safely stored to provide for safe clearance of vehicles
- Easy to connect under the vehicle
- Very flexible to compensate for vehicle misplacement
- Scissor-back storage means no wasted space

Features

- Low profile
- Long Reach
- A minimum of five planes of rotation
- Compact storage
- Torsion Spring Balanced
- Outboard two-plane swivel joint
- Available in 2", 3", 4" and 6"
- Available in steel, stainless steel, aluminum, and specialty alloys
- Choice of flanged, threaded or all-welded construction

Dimensions*

Size	A		D		T		U		R		Y		
	in.	mm	in.	mm	in.	mm	in.	mm	in.	mm	in.	mm	
2"	51	8-1/8	206	66	1676	42	1067	8-5/8	219	17	432	8-1/8	206
3"	76	10-3/4	273	66	1676	42	1067	10-1/2	267	18 1/2	470	10-3/4	273
4"	102	12-3/4	324	66	1676	42	1067	11-3/4	298	20	508	12-3/4	324
6"	152	21-1/2	546	66	1676	42	1067	19	483	24-3/4	629	18-1/2	470

*Custom dimensions also available.