

## Model BV70 Differential Control Valves

### Description

The Model BV70 Brodie Differential Control Valves are normally closed valves designed to maintain a controlled pressure differential within +/-2%.

The pilot is balanced, single seated with large ports and will operate on a differential as low as 5 PSI (34.5 kPa).

### Principle of Operation

The Valve is pilot operated and operates on a balanced piston principle, spring biased to a closed position. Pressure differential overcomes the force of the spring, causing the main valve to open and establish flow. The pilot control varies the pressure on the spring side of the piston for position.

### “AP” (Aggressive Products) Option

The “AP” option valve cylinder incorporates a combination of seals and o-ring materials to provide optimum performance in aggressive product applications. Specify “AP” Option at time of order when valve is to be used on products which may affect standard seals.

### Design Features

- Modular construction -all internal parts including seat ring can be removed with the cylinder assembly without disturbing line connections.
- No diaphragms or stuffing boxes
- 45° body design assures high capacity
- Positive shut-off
- Uniform speed of response
- Linear control characteristics
- Inherently checks reverse flow
- Characterized ports for better low flow response

### Applications

The Brodie Model BV70 is recommended for applications requiring valve closure on decreasing pressure differential, such as, pump differential control, LPG or Anhydrous Ammonia vapor control.

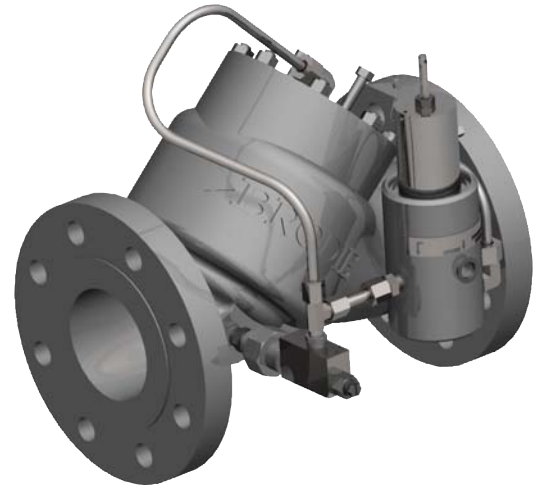

### WARNING

**Do NOT operate this instrument in excess of the specifications listed. Failure to heed this warning could result in serious injury and/or damage to the equipment.**

### Valve Capacity Data

Valve Size	2"	3"	4"	6"
*Cv-gpm	90	190	315	700

\*Cv based on wide open valve utilizing water at 60F (15.6C).

### Ordering Information

In order to accurately process an order, such information as product to be controlled, product viscosity, product temperature range, ambient temperature range, rate of flow, operating pressure, and optional features needed must be specified by the customer.

# Typical Installation

## Closed Position

The pilot is closed. The differential pressure between (P1) and (P4) is less than the pilot spring setting, indicating the pump is not running or sufficient differential pressure (P1 minus P4) is not available to overcome the pilot spring setting. Pilot is closed. Y-port (P3) to Z-port (P2) is closed. X-port (P1) and Y-port (P3) pressures are balanced. The main valve spring, being the differential force, closes the piston and keeps it seated.

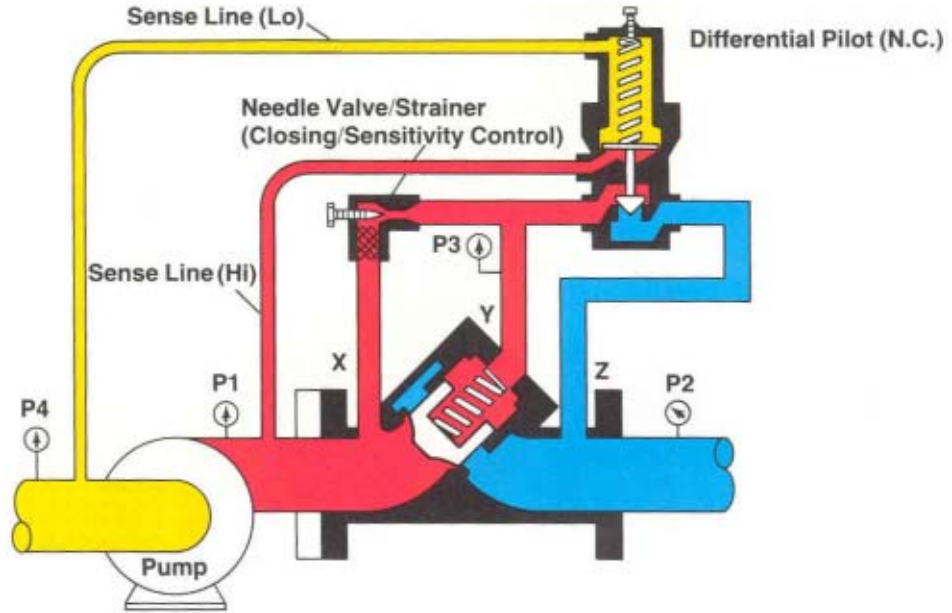

- = Inlet Pressure
- = Outlet Pressure
- = Pilot Spring Force plus P4

## Open - Controlled Position

The pilot is partially open. Differential pressure ( $P1$  minus  $P4$ ) has slightly exceeded the pilot spring setting. Z-port ( $P2$ ) is being opened by the throttling of the pilot, reducing the pressure on Y-port ( $P3$ ). The decreasing pressure at Y-port ( $P3$ ) plus the main valve spring force establishes a position of the valve piston such that it balances the pump differential pressure ( $P1$  minus  $P4$ ) equal to the pilot setting (plus or minus 2 psid).

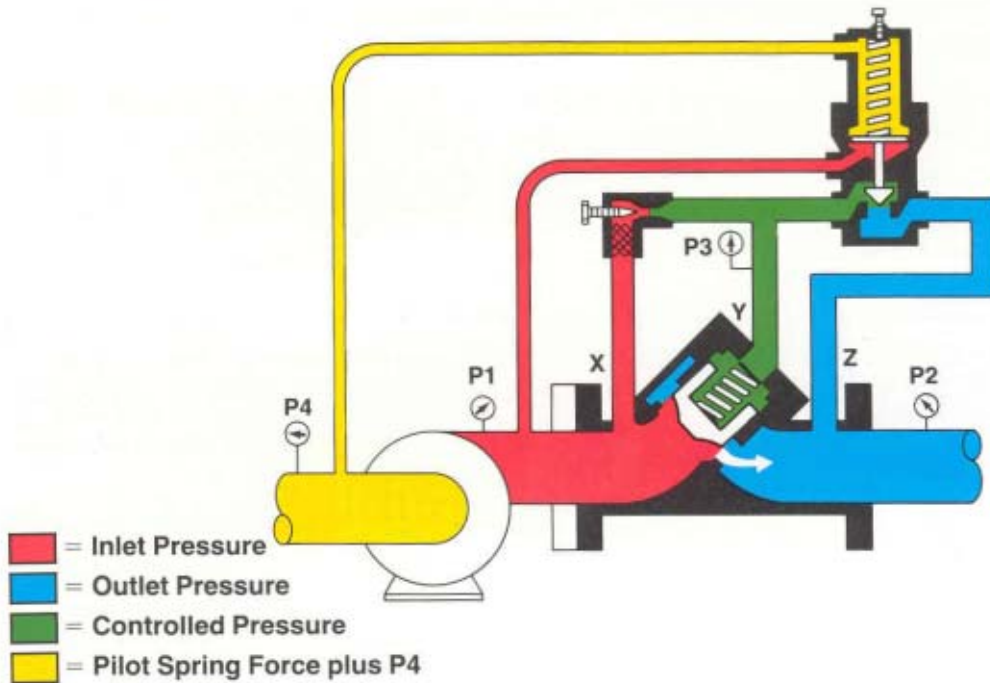

## Full Open - No Control

The Pilot is full open. Differential pressure ( $P1$  minus  $P4$ ) has exceeded the pilot spring setting. Y-port ( $P3$ ) is open to Z-port ( $P2$ ). The valve is floating the stream and is not required to control.

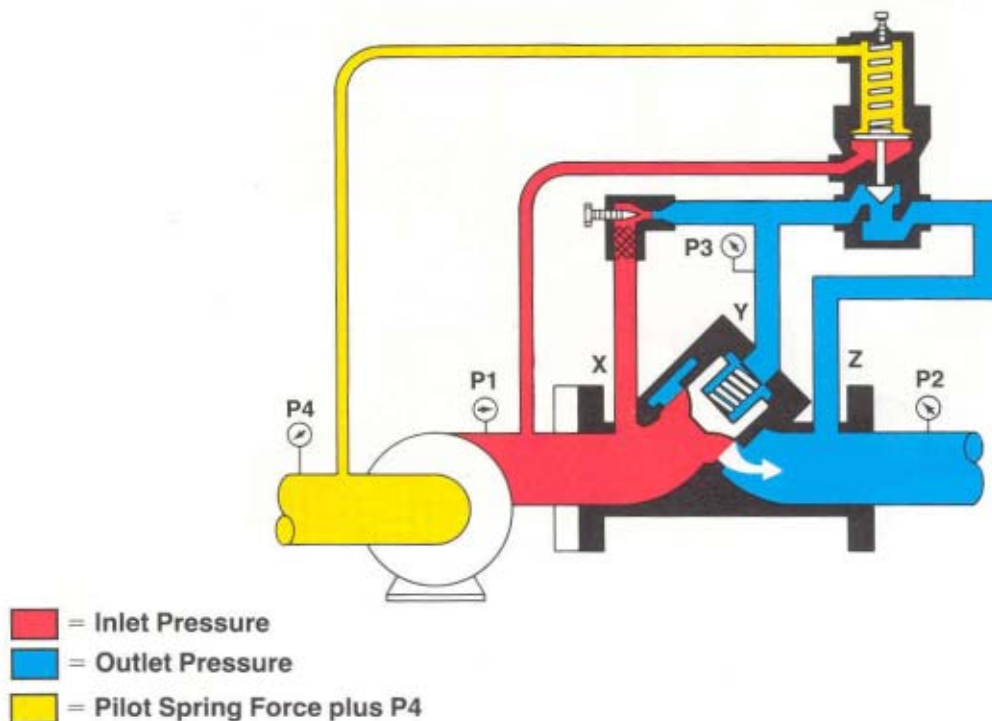

## Materials of Construction

**Main Valve Body:** Steel-ASTM-A216-GR-WCB

**Main Valve Cylinder:** 17-4 Stainless Steel, Heat Treated

**Main Valve Piston:** Stainless Steel

**Seat Ring:** Stainless Steel

**O-Rings:** Viton Standard

(Other elastomers available)

**Other Internal Parts:** Stainless Steel

**Pilot Valve Strainer/Needle Valve Strainer:**

Standard: Steel

**Tubings and Fittings:** Standard: Steel

## Optional Equipment

- Valve Position Indicator
- Position Indicator Switches
- Independent Opening Speed Control
- Stainless Steel Tubing
- Thermal Relief
- Additional Pilot Control Functions
- Pilot Line Isolation Block Valves
- Epoxy coating main valve body unmachined surfaces

## Recommended Spare Parts

O-Rings

## Pilot Spring Ranges

150-300 lb. Valves	
(PSI)	(kPa)
0-20	0-138
*0-40	0-276
30-80	207-552
70-180	483-1241
150-350	1034-2413
350-650	2413-4482

\* Spring selection based on control pressure set point.

## Flange Connections

Valve Size	Maximum Working Pressure at 100F	
	150 # ANSI	300 # ANSI
2" - 6"	285 PSI	740 PSI

## Dimensions (For Certified Dimensional Prints - Consult Factory)

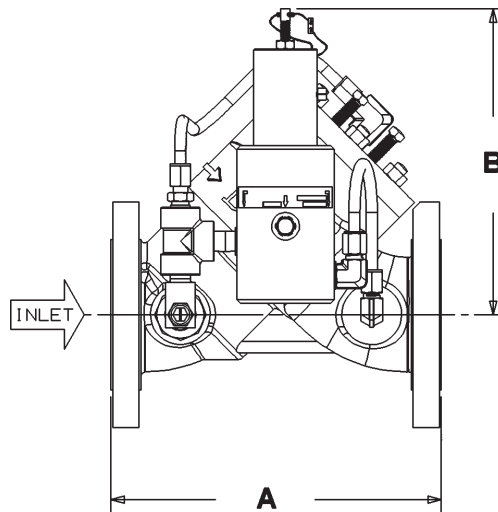

Valve Size	Dimension A				Dimension B	
	150#		300#		150#-300#	
	Inches	mm	Inches	mm	Inches	mm
2"	10 1/4	260	10 1/2	267	10 7/8	276
3"	11	279	13 1/8	333	11.25	286
4"	13	330	14 1/2	368	11.5	292
6"	17	432	17 7/8	454	13 5/8	346

The contents of this publication are presented for informational purposes only, and while every effort has been made to ensure their accuracy, they are not to be construed as warranties or guarantees, express or implied, regarding the products or services described herein or their use or applicability. Brodie Meter Co., LLC reserves the right to modify or improve the designs or specifications of such products at any time without notice.

**BRODIE**  
International

19267 Highway 301 North (30461)  
PO Box 450 • Statesboro, GA 30459-0450  
Phone: (912) 489-0200 • Fax: (912) 489-0294  
[www.brodieintl.com](http://www.brodieintl.com)