



## Regulator Installation and Maintenance Instructions

# Model 141-A Regulators

## Introduction

The Model 141-A regulator is both easy to use and durable for high pressure jobs. Thus, these field regulators work great on small and intermediate size loads on gas transmission lines.

The Model 141-A regulator is best known for its use on pipeline taps serving remote farm, domestic, commercial, and industrial applications.

Use them also on other high pressure loads – producer field work, high pressure burners, compressed air, and other high pressure applications. The 141-A is meant for pound-to-pound cuts on natural gas, but works equally well on air, nitrogen, LP gases, dry CO<sub>2</sub>, and other gases.

MODEL	PIPE SIZES (screwed NPT)	CONSTRUCTION		OUTLET PRESSURE RANGE	ORIFICE SIZES
		Body	Upper Case		
141-A	2"	Ductile Iron	Cast Iron	3 to 400 psi	1/8" through 7/8"

1. Follow these REGULATOR INSTALLTION & MAINTENANCE INSTRUCTIONS for this regulator in installing, operating, and servicing it. **KEEP THIS BULLETIN FOR REFERENCE.** Installation, operating, and servicing must only be done by qualified persons.
2. Comply with all rules, regulations, and codes (Federal, State, Local, and Insurance).
3. Inspect the regulator periodically to make sure it is in satisfactory working condition. Establish how often on the basis of severity of service and applicable laws and regulations.
4. If the regulator is to be moved to another location, make sure its construction is compatible with the new pressure and flow conditions.
5. If any of these instructions are not understood or there are any questions, phone your Equimeter sales office.

## Maximum Inlet Pressures

ORIFICE SIZE						
1/8"	1/4"	3/8"	7/16"	1/2"	5/8"	7/8"
MAXIMUM INLET PRESSURE psi						
1500	1000	400	300	200	150	50

## Preparation

1. Examine the regulator for shipping damage.
2. Check the name plate data. Make sure the regulator conforms with what was ordered.
3. Provide suitable, conveniently located stop valves.

4. Protect the regulator from damage by vehicles or other outside sources.

5. Inside of regulator and piping must be clean. Remove all dirt and debris before installing the regulator. Failure to do this could result in regulator trouble or damage.

### NOTE

*Where there are dirt problems in the gas, it may be necessary to install a suitable filter or strainer ahead of the regulator. Dirt or debris in the gas can damage the regulator.*

6. Remove all shipping screens and covers from the regulator. It is best to do this just before installing it. Do not let dirt get inside.

## Installation, Adjustment, and Start-Up

1. Screwed connections must conform with good piping practice free of excess thread engagement (ANSIB2-1). Apply pipe joint compound to male threads only.

2. Install regulator. Make certain it is piped up correctly (with inlet pipe connected to the regulator inlet connection) and flow is in the right direction. Regulator may be installed in any position: right side up, upside down, vertical pipe, horizontal pipe, etc.

**The diaphragm case vent must be positioned to protect against flooding, drain water, ice formation, traffic, tampering, etc. The vent must be protected against nest building animals, bees, insects, etc. to prevent vent blockage and minimize the chances for foreign material from collecting in the vent side of the regulator diaphragm.**

### CAUTION

*It is the user's responsibility to assure that all regulator vents and/or vent lines exhaust to a non-hazardous location away from any potential sources of ignition. Where vent lines are used, it is the user's responsibility to assure that each regulator is individually vented and that common vent lines are not used.*

3. Before beginning startup, make sure regulator is correctly connected and pipe joints are tight.

4. Note the set-point (set-point is the outlet pressure the regulator is adjusted to deliver). Regulator is factory adjusted to the set-point specified on the order.

5. Turn gas on very slowly. Open outlet stop valve first. Do not overload the diaphragm with a sudden surge of pressure.

6. Make certain there are no leaks.

## CAUTION

***During startup a pressure gauge must be used on the piping at the regulator outlet and closely watched. While inlet pressure enters the regulator, outlet pressure must not exceed set-point by more than the small amount needed for lock-up (tight shutoff). If outlet pressure continues to increase above this, close the inlet shut off valve -- the regulator is not closing properly. Make necessary corrections before resuming startup. Regulator must be fully capable of tight lock-up.***

- 7** Adjust set-point (outlet pressure) by turning adjustment screw **(2)** (see page 3). Turn clockwise to increase and counterclockwise to decrease. Be sure to replace seal cap **(1)** after adjustment is completed.

Do not adjust where regulator is closed (no flow). Only adjust when gas is flowing through regulator. Except for lock-up (regulator closed), the outlet pressure during normal operation must not go higher than the maximum limit of the spring range. Whenever it goes higher, the spring could be overstressed. Also, the higher pressure springs could compress solid and thereby keep the regulator from closing.

Therefore, whenever set-point is within the upper third of the spring range, set-point adjustment should be made at low flow (less than 10 percent of regulator capacity table value). If set-point adjustment must be made when flow is greater, use the next higher range spring.

## CAUTION

***Turn gas on very slowly. If an outlet stop valve is used, it should be opened first. Do not overload diaphragm with a sudden surge of inlet pressure. Monitor the outlet pressure during start-up to prevent an outlet pressure overload.***

- 8** The vent connection is an escape path for flammable gas and it must be located and/or piped so that potential discharge occurs in a safe area away from buildings, open flames, collection areas, arcing devices, etc.

**Regulators that are installed indoors or in a non-vented area must be vented to the outside. Simply run vent piping from the regulator vent connection to a non-hazardous location on the outside away from any potential sources of ignition. The vent piping must be connection size or larger and piped to a safe area. The vent discharge must be protected against the potentials outlined in Installation, Adjustment, and Start-up (#2, #8, and #9).**

**The outlet of the vent piping must allow for the free and unobstructed passage of air and gas and must be protected against the potentials listed in Installation, Adjustment, and Start-up (#2, #8, and #9).**

- 9** For outdoor installations, it is recommended that the regulator be installed so that the regulator vent faces downward to avoid the potential for water or other foreign matter entering the regulator and interfering with the proper operation of the regulator.

## CAUTION

***Regulators are pressure control devices with numerous moving parts subject to wear that is dependent upon particular operating conditions. To assure continuous satisfactory operation, a periodic inspection schedule must be adhered to with the frequency of inspection determined by the severity of service and applicable laws and regulations.***

## Warning

- 1** Do not exceed the regulator's pressure ratings. Over-pressuring the regulator could damage it internally, cause leaks or even result in personal injury by bursting a pressure containing part.  
The regulator outlet has a lower pressure rating than the inlet. Do not expose the regulator outlet to inlet pressure.
- 2** Overpressure protection may be needed. If inlet pressure is, or could be, greater than the regulator's emergency rating for outlet pressure, install suitable over-pressure protection to prevent regulator damage or personal injury (See "Maximum Emergency Pressures" on page 5).
- 3** Prompt attention is essential if there is regulator trouble; if gas leaks from the vent or elsewhere from the regulator; or if leaks develop in the piping. Failure to shut off the gas and shut down the regulator may cause serious hazards.
- 4** Do not use the regulator on corrosive gases unless authorized by Equimeter for a specific corrosive condition.

## Servicing

- 1** Before any disassembly of the regulator, make sure it is completely depressured. Pressure must be fully released from the inlet, the outlet, and the control line connection. Failure to adequately depressure could result in serious personal injury.
- 2** Carefully note location and position of each part during disassembly to make certain reassembly is correct. Replace all worn, damaged or otherwise unsatisfactory parts.
- 3** To change spring **(5)**, remove seal cap **(1)** and turn adjustment **(2)** counterclockwise until spring compression is fully released. Then remove bolts **(8)** and remove upper case **(6)**.

When reinserting spring, make sure it is correctly positioned top and bottom before installing bolts (8). Diaphragm (11) must also be correctly positioned and must not be twisted or pinched. Tighten bolts (8) evenly and firmly.

When changing to a different spring, make sure the correct combination of diaphragm (Part (11)), upper diaphragm plate (Part (10) or (19a)) and ring (Part (19b)) is used as specified in the "Outlet Pressure Ranges" table on page 5.

- 4** To replace diaphragm (11), first remove spring (5) and uppercase (6) per instructions in the first paragraph of 3 above, and remove the diaphragm assembly. Remove nut (7) to disassemble the diaphragm assembly.

Note instructions in the second paragraph of 3 above upon reassembly.

- 5** To service valve and lever assembly (16), first remove the diaphragm assembly per instructions in 4 above. Remove screws (17) and remove assembly.

Remove hairpin cotter (16c) to remove valve (16b). Remove retaining ring (16g) to remove stem (16d).

Note instructions in the second paragraph of 3 above upon reassembly.

- 6** To replace orifice (14), disconnect inlet pipe connection or remove regulator from line. Access to the orifice is through the regulator inlet.

Use the following Allen wrenches or equivalent to remove and install orifices:

2" Model 141-A . . . 1" Allen wrench  
(1" across flats).

- 7** Adjustment screw lubrication should be checked whenever the regulator is serviced. Make sure the threads are fully coated with lubricant.

Where there is evidence of thread wear, such as a loose fit or excessive sideplay, the worn parts must be replaced.

### NOTE

***Even at only 10 psig outlet pressure, the force exerted on the adjustment screw by spring compression can be great. As a result, failure from worn threads could result in serious personal injury. Therefore, adjustment screw lubrication and thread condition must be given careful attention.***

- 8** Upon completion of servicing, make certain that the regulator installation is entirely free of leaks.

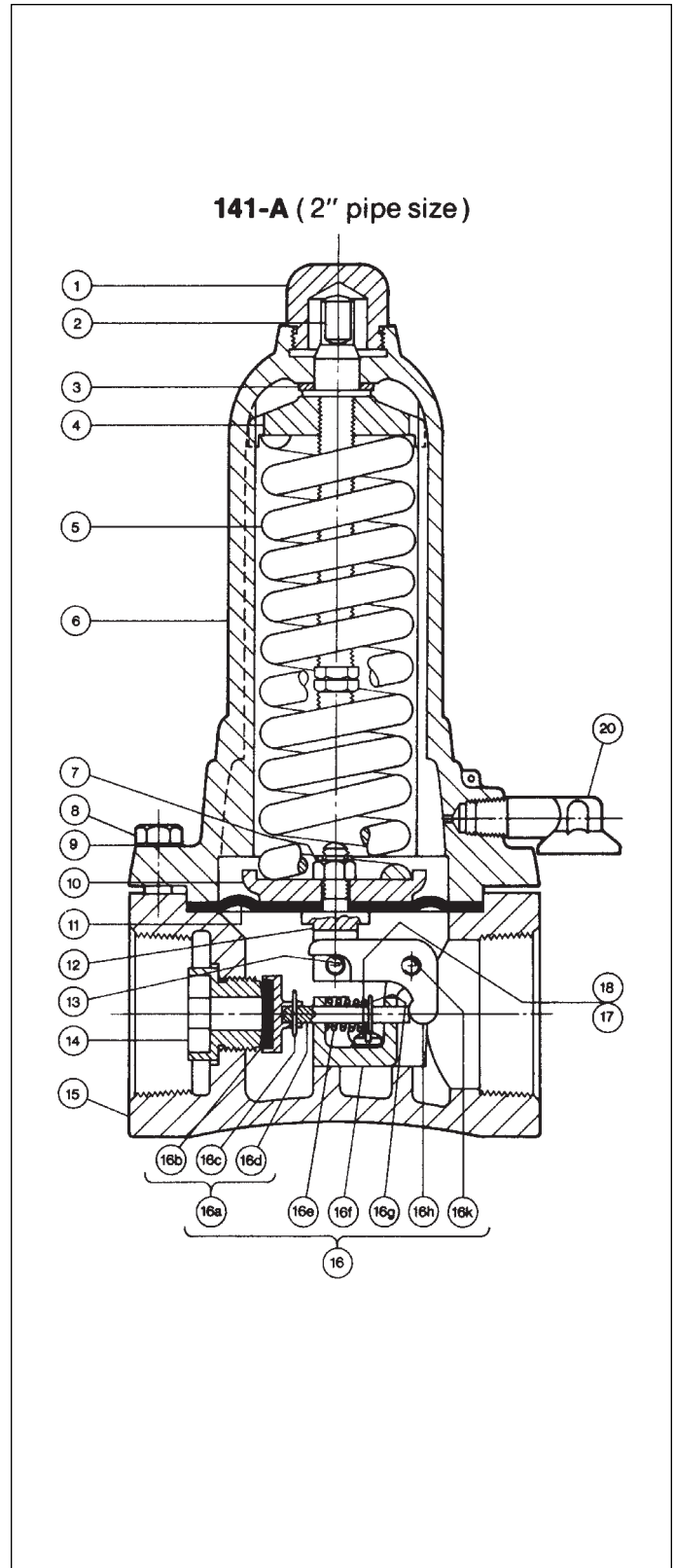

## Condensed Parts List

ILL. NO.	DESCRIPTION	PART NUMBER
3	Adjustment Screw Bearing Disc	141-10-160-01
5	Spring (see table, page 5, Outlet Pressure Ranges)	
5a	Inner Spring (see table, page 5, Outlet Pressure Ranges)	
7	3/8" - 16 "Flexloc" Nut	900123
10	Upper Diaphragm Plate (see table, page 5, Outlet Pressure Ranges)	
11	Diaphragm (see table, page 5, Outlet Pressure Ranges)	
12	Diaphragm Stem	141-10-028-00
13	Diaphragm Stem Pin	901702
14	Orifices for 2" Model 141-A	
	1/8", Brass	141-10-023-07
	1/4", Brass	141-10-023-09
	3/8", Brass	141-10-023-10
	1/2", Brass	141-10-023-11
	5/8", Brass	141-10-023-12
	7/8", Brass	141-10-023-13
	1/8", Stainless	141-10-023-23
	1/4", Stainless	141-10-023-21
	3/8", Stainless	141-10-023-20
	1/2", Stainless	141-10-023-24
	5/8", Stainless	141-10-023-25
	7/8", Stainless	141-10-023-26
16	Lever and Valve Assembly, L.P. Polyurethane (tan) and brass stem	141-10-530-13
	Lever and Valve Assembly, H.P. Polyurethane (green) and brass stem	141-10-530-15
	Lever and Valve Assembly, L.P. Polyurethane (tan) and stainless steel stem	141-10-530-14
	Lever and Valve Assembly, H.P. Polyurethane (green) and stainless steel stem	141-10-530-16
	Lever and Valve Assembly, H.P. Nylon (white) and brass stem	141-10-530-17
	Lever and Valve Assembly, H.P. Nylon (white) and stainless steel stem	141-10-530-18
16a	Valve and Stem Assembly, L.P. Polyurethane (tan) and brass stem	141-10-611-13
	Valve and Stem Assembly, H.P. Polyurethane (green) and brass stem	141-10-611-15
	Valve and Stem Assembly, L.P. Polyurethane (tan) and stainless steel stem	141-10-611-14
	Valve and Stem Assembly, H.P. Polyurethane (green) and stainless steel stem	141-10-611-16
	Valve and Stem Assembly, H.P. Nylon (white) and brass stem	141-10-611-17
	Valve and Stem Assembly, H.P. Nylon (white) and stainless steel stem	141-10-611-18

ILL. NO.	DESCRIPTION	PART NUMBER
16b	Molded Valve, L.P. Polyurethane (tan) for differentials to 300 psi maximum	141-10-511-09
	Molded Valve, H.P. Polyurethane (green) for high differentials	141-10-511-10
16c	Hairpin Cotter	143-62-118-00
16d	Valve Stem, Brass	141-10-016-02
	Valve Stem, Stainless	141-10-016-04
16e	Valve Stem Spring	141-10-021-00
16f	Lever Bracket	141-10-068-00
16g	Retaining Ring	904680
16h	Lever	141-10-030-00
16k	Lever Bracket Pin	904232
17	5/16" - 18 x 5/8" Fil. Hd. Stl. Mach. Screw	919903
18	5/16" Stl. Shakeproof Internal Lockwasher	904017
19a	Upper Diaphragm Plate for Outlet Pressures to 400 psi (see table, page 5, Outlet Pressure Ranges)	
19b	Ring Use with Upper Diaphragm Plate 19a (see table, page 5, Outlet Pressure Ranges)	
20	1/4" NPT Vent Cap Assembly	137-02-505-03

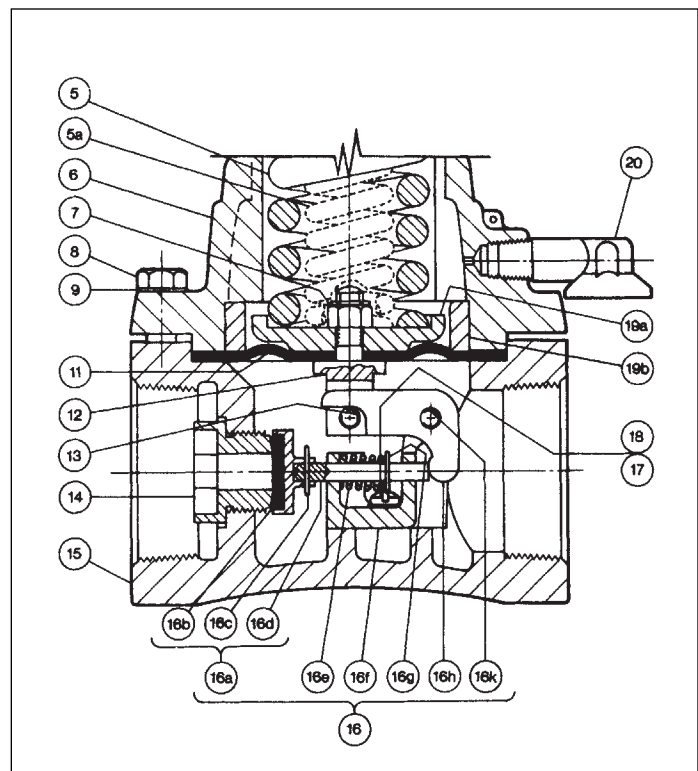

## Full Open Capacity

Capacity for the full open valve position can be calculated using the following formulas and K factors (Do not use full open capacity when sizing one of these regulators for an application. Instead, use the capacity tables on pages 4, 5, and 6 of Bulletin R-1311):

$$1. Q = K \sqrt{P_0 (P_1 - P_0)}$$

$$2. Q = \frac{KP_1}{2}$$

Q = full open capacity of the regulator in SCFH of 0.6 specific gravity natural gas.

K = the "K" factor; the regulator constant (from table below)

P = absolute inlet pressure (psia)

P = absolute outlet pressure (psia)

Use formula 1 when  $\frac{P_1}{P_0}$  is less than 1.894.

Use formula 2 when  $\frac{P_1}{P_0}$  is greater than 1.894.

ORIFICE	K
1/8"	33
1/4"	132
3/8"	292

ORIFICE	K
7/16"	400
1/4"	520
3/8"	820
7/8"	900

Remember, at the above full open capacities the droop is greater than specified in the capacity tables on page 4 of Bulletin R-1311.

When sizing relief valves for these regulators, use the above calculated full open capacity. Do not use capacity values from tables on page 4 of Bulletin R-1311.

## Dimensions

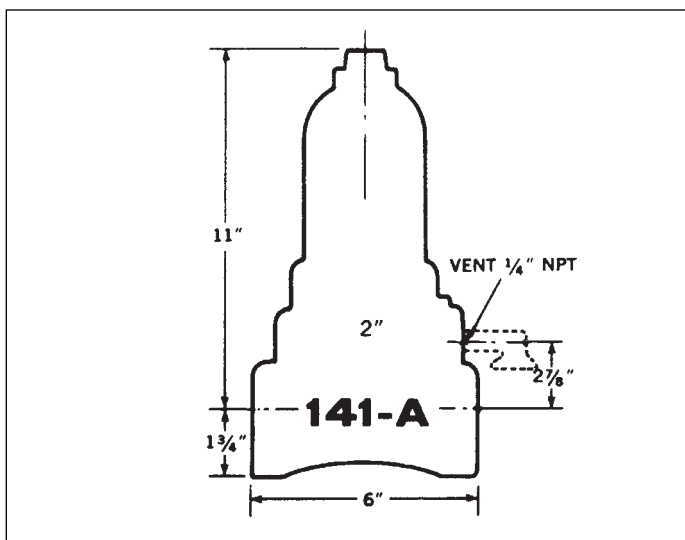

## Maximum Emergency Pressures

The maximum inlet pressures Model 141-A regulators may be subjected to under abnormal conditions without causing damage are as follows:

ORIFICE SIZE						
1/8"	1/4"	3/8"	7/16"	1/2"	5/8"	7/8"
PRESSURE psi						
1650*	1150*	550	450	350	300	200

\*Green polyurethane soft seats only. If tan polyurethane seats are used, pressure is 700 psi.

The maximum pressures the diaphragms may be subjected to under abnormal conditions without causing internal damage are as follows:

- Standard (set-points to 250 psi) .....set-point + 100 psi
- High Pressure Diaphragm Assembly .....set-point + 150 psi

Set-point is defined as the outlet pressure a regulator is adjusted to deliver.

If any of the above pressure limits are exceeded, the regulator must be taken out of service and inspected. Damaged or otherwise unsatisfactory parts must be repaired or replaced before returning the regulator to service.

The maximum outlet pressure that can be safely contained by the diaphragm/spring case of Model 141-A regulators is 800 psi. Safely contained means no leakage as well as no bursting.

Before using any of the above data, make sure this entire section is clearly understood.

## Over Pressurization Protection

Protection must be provided for the downstream piping system and the regulator's low pressure chambers to assure against the potential over-pressurization due to a regulator malfunction or a failure of the regulator to lock-up. The allowable over-pressurization is the lowest of the maximum pressures permitted by federal codes, state codes, Equimeter Bulletin RDS-1498, or other applicable standards. The method of providing over-pressure protection could be a relief valve, a monitor regulator, a shut-off device or any similar device.

## Outlet Pressure Ranges

OUTLET PRESSURES	SPRING PART NUMBER	COLOR CODE	DIAPHRAGM	ASSEMBLY
3 to 12 psi	138-02-021-00	Yellow	1/16" thick (141-10-150-01)	Standard Upper Diaphragm Plate (141-10-022-02)
10 to 50 psi	138-02-021-02	Aluminum		
50 to 150 psi	138-02-021-04	Tan	1/8" thick (141-10-150-00)	High Pressure Upper Diaphragm Plate and Loading Ring (141-10-022-03) (141-10-002-00)
100 to 250 psi	138-02-021-11	Gray		
200 to 400 psi	138-02-021-11			

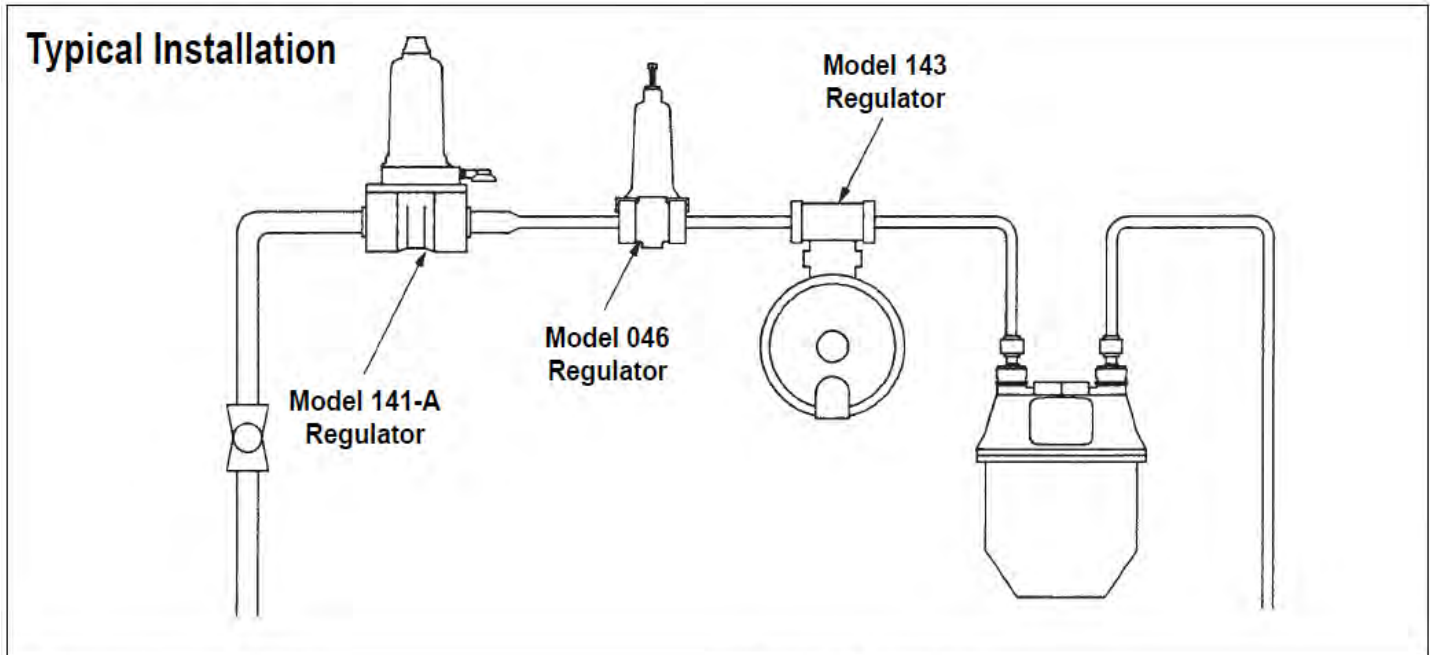

## Temperature Limits

The Model 141-A Regulator can be used for flowing temperatures from  $-20^{\circ}\text{F}$ . to  $150^{\circ}\text{F}$ .

## Buried Service

The Model 141-A Regulator is not recommended for buried service.

## Authorized Distributor

**SENSUS**

805 Liberty Boulevard  
 DuBois, PA 15801  
 814-375-8875  
 Fax 814-375-8460

### Limited Warranty

Seller warrants the Goods to be free from defects in materials manufactured by Seller and in Seller's workmanship for a period of one (1) year after tender of delivery (the "Warranty Period"). THIS LIMITED WARRANTY (a) IS IN LIEU OF, AND SELLER DISCLAIMS AND EXCLUDES ALL OTHER WARRANTIES, STATUTORY, EXPRESS OR IMPLIED, INCLUDING, WITH LIMITATION, ANY WARRANTY OF MERCHANTABILITY OR FITNESS FOR A PARTICULAR PURPOSE, OR OF CONFORMITY TO MODELS OR SAMPLES; (b) does not apply to any Goods which have been (i) repaired, altered or improperly installed; (ii) subjected to improper use or storage, (iii) used or incorporated with other materials or equipment, after buyer or anyone using the Goods has, or reasonably should have, knowledge of any defect or nonconformance of the Goods; or (iv) manufactured, fabricated or assembled by anyone other than Seller, (c) shall not be effective unless buyer notifies Seller in writing of any purported defect or nonconformance with (thirty days) after Buyer discovers or should have reasonably discovered such purported defect or nonconformance; and (d) shall only extend to Buyer and not to any subsequent buyers or users of the Goods. Buyer shall provide Seller access to the Goods as to which Buyer claims a purported defect or nonconformance, upon request by Seller, buyer shall, at its own risk and expense, promptly return the Goods in question to Seller's Plant.